

PS Series

for Single Base & 1 Protection Module

Type 1CA (Din-rail Mounting SPDs)

UL recognized Type 1CA surge protective device is especially designed for low-voltage power supply system surge protection, especially for point of entry (Category C,D, ANSI/IEEE C62.41) and sub-circuit (Category B, ANSI/IEEE C62.41) protection.

UL recognized Type 1CA SPD, passed short circuit current rating (SCCR) 200kA without external fuse or CB..

High reliability due to global patented thermally protected MOV with special arc-extinguish device (TPAE technology).

Large surge energy capability up to 50KA per mode.



Specifications

- Cross-section of connection wire : Single-strand 35mm² or # 2AWG Multi-strand 25mm² or # 4AWG
- Mounting : 35mm DIN-rail in accordance with EN 50022/DIN46277-3
- Enclosure material : thermoplastic; extinguishing degree UL94 V-0
- Degree of protection : IP20
- Thermal disconnecter : Internal green – normal ; red - failure
- Switching capability Un/In : AC : 250V/0.5A DC: 250V/0.1A 125V/0.2A 75V/0.5A
- Max. Size of Remote connecting wire : Max. 1.5mm²(or # 16AWG)

Model No.	PS150-S	PS180-S	PS275A-S	PS320-S	PS420-S	PS550-S	PS690-S
Rated System Voltage	Single Phase 2W						
	120V	127V	220/230V	240/277V	347V	480V	660V
MCOV (Vac)	150	180	275	320	420	550	690
I_n (kA) -8/20 μ S- / I_{max} (kA) -8/20 μ S-	20 / 50						20 / 40
VPR(Vpk) (kV)	0.7	1.0	1.2	1.5	1.8	2.5	
SCCR(kA)	200						

Basic Circuit Diagram

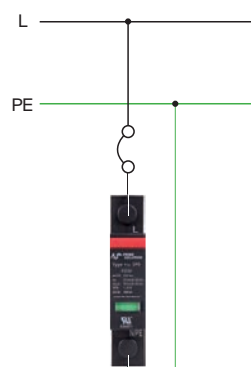
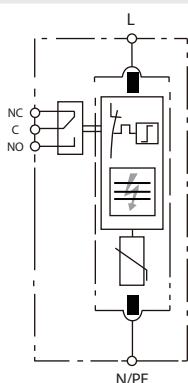

Model No.	PS150T-S	PS255T-S
Rated System Voltage	Single Phase 2W GDT for N-G	
	120V	220 / 230 / 240V
MCOV (Vac)	150	255
I_n (kA) -8/20 μ S- / I_{max} (kA) -8/20 μ S-	20 / 50	
VPR(Vpk) (kV)	0.9	
SCCR(kA)	200	

● Basic Circuit Diagram

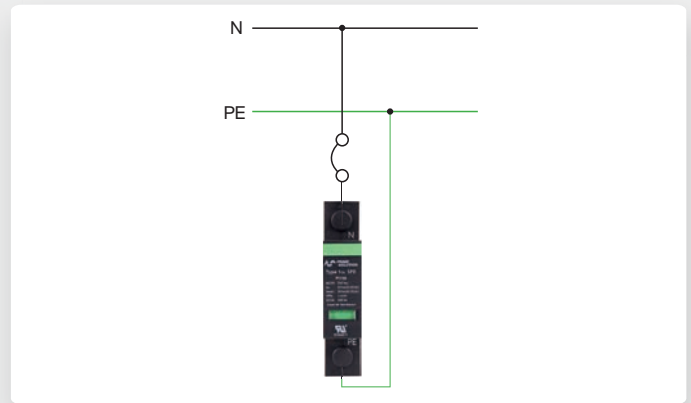
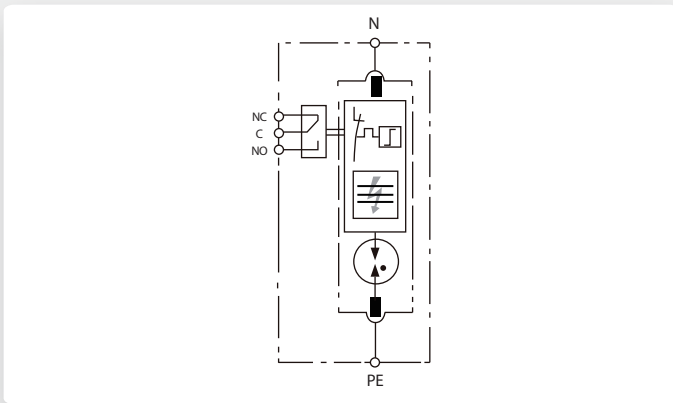

● Dimension

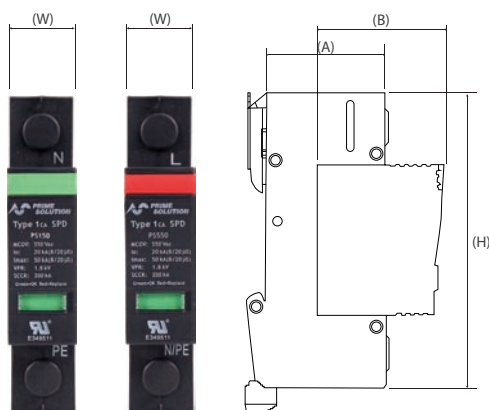

	Size (inch/mm)
W	0.71 / 18
H	3.54 / 90
A	1.98 / 50.2
B	2.53 / 64.3



HEAD OFFICE

3960 West Point Loma Blvd, Ste. H San Diego, CA 92110

John Park Director / Technical Support Dept.

Tel : +1-858,282,0901

johnpark@primepowersolutions.com

www.PrimePowerSolutions.com